

# GARDNER DENVER SW400/550

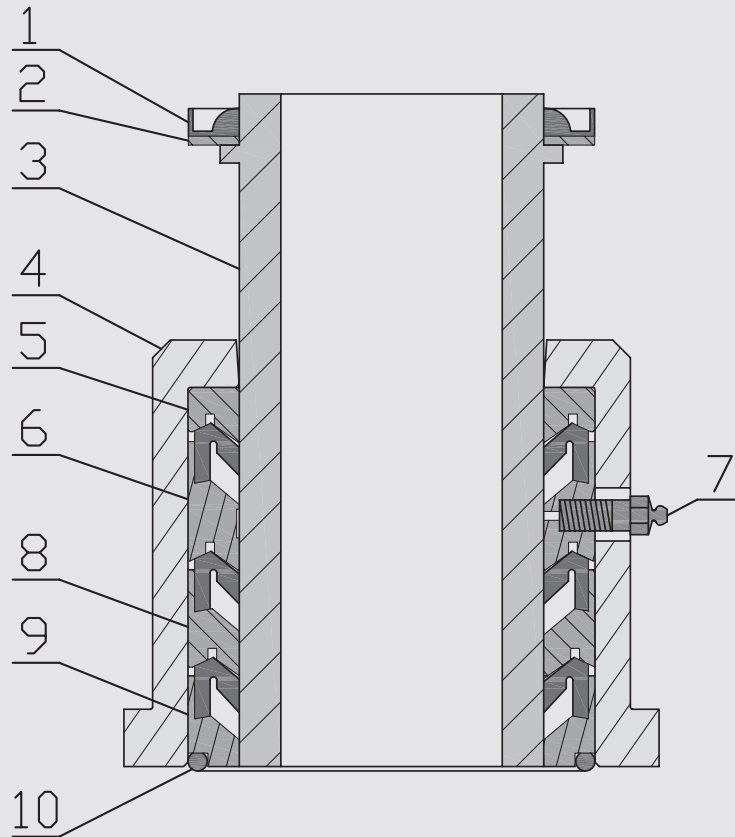

Item#	Qty	Description	SW400/550
1	1	Washpipe Packing (Includes 4 Packing Rings and Item 10)	SW-75-116-2
2	1	Packing Ring	SW-126961
3	1	Washpipe	SW-70-116-2
4	1	Packing Box	SW-185303
5	1	Top Spacer	SW-185304
6	1	Spacer Ring	SW-185305
7	1	Grease Fitting	SW-118043
8	1	Middle Spacer	SW-185306
9	1	Bottom Spacer	SW-185307
10	1	O-Ring	SW-162810